



Polyester Injection System with ETA Assessment Option 7 for Non-Cracked Concrete. SA TS 101:2015 Compliant



Suitable Anchor Rods M8 - M24

- Steel 5.8 and 8.8 Zinc Plated and Hot Dip Galvanized
- Stainless Steel A4-70
- High Corrosion Resistant Steel 1.4529

Use Conditions

- Installation in Non-Cracked Concrete C20/25 to C50/60 according to EN 206-1:2000 and SA TS 101:2015
- For Static and quasi static loading
- In Dry, Wet & Flooded Holes
- Structures subject to dry internal and permanent damp internal conditions.
- Structures subject to external atmospheric exposure.
- Overhead Installation allowed.

Typical Applications

- Infrastructure Construction (Roads, Viaducts, Sound Barriers, Crash Barriers, Harbours, High Rise Construction, Steel Construction)
- Production Facilities (Installation of Cranes, Robots, Conveyor Lines etc.)

Approvals & Test Reports

B+BTec Muntenrij 8, NL 4762AH, Zevenbergen 15 		ÉMISSIONS DANS L'AIR INTÉRIEUR™
1343 1343-CPR-M 529-5 ETA-15/0526 ETAG 001-5 Option 7 M8 - M24 European Technical Assessment Option 7 for non cracked concrete DoP: 1343-CPR-M 529-5		 NATIONAL CODE COMPLIANT

Installation Procedures

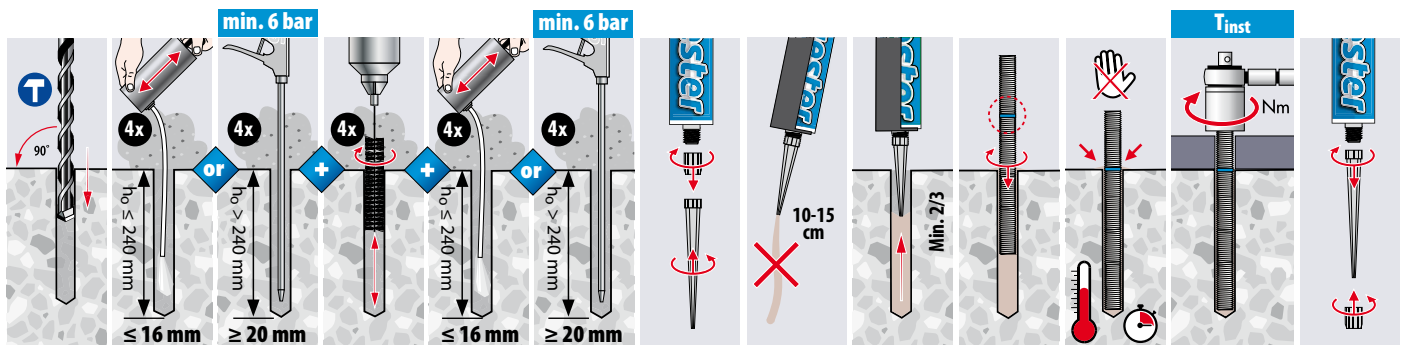

Curing Times

Temperature ¹⁾	°C	-5	+0	+5	+10	+20	+30	+35
Processing Time		90 min	45 min	25 min	20 min	6 min	4 min	2 min
Curing Time Dry Holes		6 h	3 h	2 h	100 min	45 min	25 min	20 min

1) Concrete Temperature

Supplied by



Making your job easier!

09 42 68 101

sales@everitts.co.nz

www.everitts.co.nz

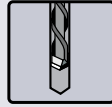

Specification Data for the use in Non-Cracked Concrete and Hammer/Air Drilled Holes according to SA TS 101:2015

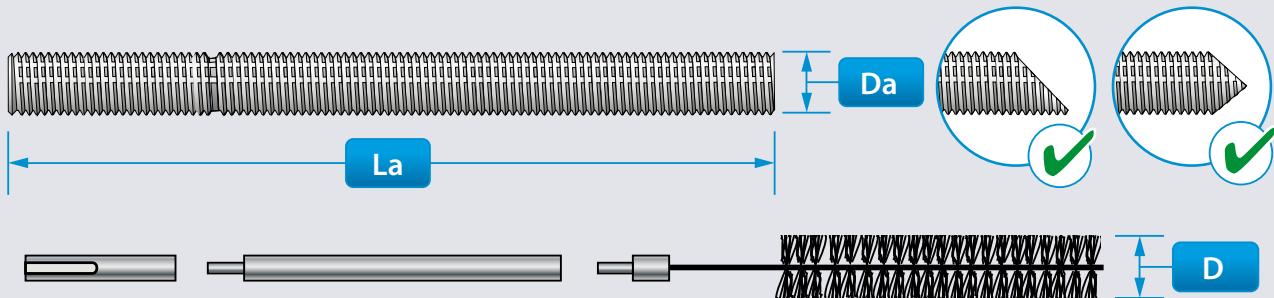

Installation Dimensions

Anchor Size	D _a		M8	M10	M12	M16	M20	M24
Rod Length	La ≥	[mm]	110	130	160	190	260	300
Hole Diameter	d_o	[mm]	10	12	14	18	24	28
Embedment Depth	h_o=h_{ef}	[mm]	80	90	110	125	170	210
Diameter Fixture Hole	d_f	[mm]	9	12	14	18	22	26
Fixture Thickness	t_{fix} ≤	[mm]	20	30	35	45	70	65
Recommended Torque	T_{inst}	[Nm]	10	20	40	80	120	160
Required Volume per cm Embedment Depth	V_s	[ml/cm]	0,44	0,59	0,75	1,09	2,25	2,87

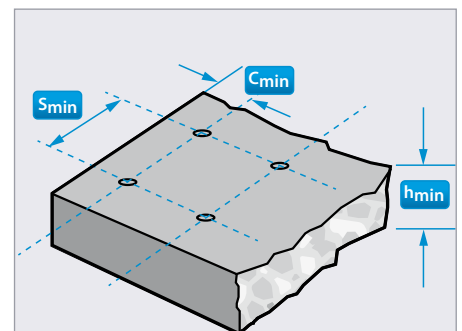
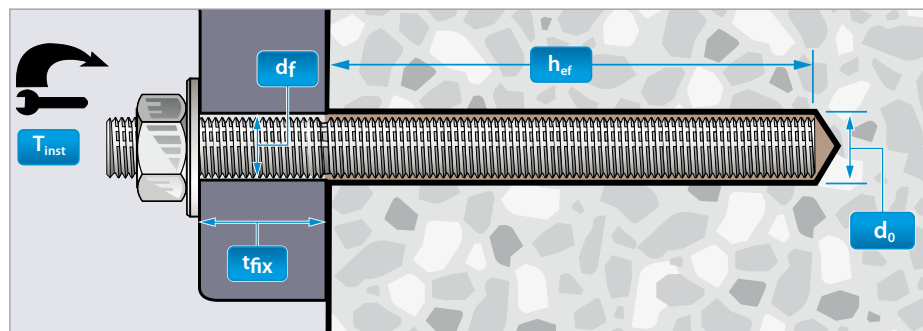

Member Thickness, Edge Distance & Spacing

Anchor Size	D _a		M8	M10	M12	M16	M20	M24
Min. Member Thickness	h_{min}	[mm]	110	120	140	160	215	270
Min. Edge Distance	C_{min}	[mm]	40	50	60	80	100	120
Min. Spacing	S_{min}	[mm]	40	50	60	80	100	120

Steel Brush Dimensions

Anchor Size	D _a		M8	M10	M12	M16	M20	M24
Brush Diameter	D	[mm]	12	14	16	20	26	30
Min. Brush Diameter	D_{min}	[mm]	10,5	12,5	14,5	18,5	24,5	28,5

Supplied by



Making your job easier!

09 42 68 101

sales@everitts.co.nz

www.everitts.co.nz



Performance Data¹⁾ for Hammer/Air Drilled Holes in Non-Cracked Concrete

- Performance Data:** Loads in kN for a single anchor in Non-Cracked Concrete C20/C25*.
Temperature 24°C/40°C for long/short term. No influence of Edge- or Center to Center Distances.
Increasing factors for concrete ψ : **C30/37:** 1,08 **C40/50:** 1,15 **C50/60:** 1,19
- Shear Loads:** Steel strength in kN without bending moment.
- Recommended Loads** incl. Safety factor $\gamma_G = 1,4$.

Steel Failure

Characteristic Resistance Dry/Wet Holes

Non-Cracked Concrete		D _a		M8	M10	M12	M16	M20	M24
Steel 5.8	Tensile	N_{Rk}	[kN]	17,1	22,6	33,2	50,3	85,5	126,7
	Shear ²⁾	V_{Rk}	[kN]	9,0	14,0	21,0	39,0	61,0	88,0
Steel 8.8	Tensile	N_{Rk}	[kN]	17,1	22,6	33,2	50,3	85,5	126,7
	Shear ²⁾	V_{Rk}	[kN]	15,0	23,0	34,0	63,0	98,0	141,0
A4-70	Tensile	N_{Rk}	[kN]	17,1	22,6	33,2	50,3	85,5	126,7
	Shear ²⁾	V_{Rk}	[kN]	13,0	20,0	30,0	55,0	86,0	124,0

Characteristic Resistance Flooded Holes

Non-Cracked Concrete		D _a		M8	M10	M12	M16	M20	M24
Steel 5.8	Tensile	N_{Rd}	[kN]	17,1	22,6	33,2	50,3	n/a	n/a
	Shear ²⁾	V_{Rd}	[kN]	9,0	14,0	21,0	39,0	n/a	n/a
Steel 8.8	Tensile	N_{Rd}	[kN]	17,1	22,6	33,2	50,3	n/a	n/a
	Shear ²⁾	V_{Rd}	[kN]	15,0	23,0	34,0	63,0	n/a	n/a
A4-70	Tensile	N_{Rd}	[kN]	17,1	22,6	33,2	50,3	n/a	n/a
	Shear ²⁾	V_{Rd}	[kN]	13,0	20,0	30,0	55,0	n/a	n/a

3

Design Resistance Dry/Wet Holes

Non-Cracked Concrete		D _a		M8	M10	M12	M16	M20	M24
Steel 5.8	Tensile	N_{Rd}	[kN]	9,5	12,6	18,4	27,9	47,5	70,4
	Shear ²⁾	V_{Rd}	[kN]	7,2	11,2	16,8	31,2	48,8	70,4
Steel 8.8	Tensile	N_{Rd}	[kN]	9,5	12,6	18,4	27,9	47,5	70,4
	Shear ²⁾	V_{Rd}	[kN]	12,0	18,4	27,2	50,4	78,4	112,8
A4-70	Tensile	N_{Rd}	[kN]	9,5	12,6	18,4	27,9	47,5	70,4
	Shear ²⁾	V_{Rd}	[kN]	8,3	12,8	19,2	35,3	55,1	79,5

Design Resistance Flooded Holes

Non-Cracked Concrete		D _a		M8	M10	M12	M16	M20	M24
Steel 5.8	Tensile	N_{Rd}	[kN]	9,5	12,6	18,4	27,9	n/a	n/a
	Shear ²⁾	V_{Rd}	[kN]	7,2	11,2	16,8	31,2	n/a	n/a
Steel 8.8	Tensile	N_{Rd}	[kN]	9,5	12,6	18,4	27,9	n/a	n/a
	Shear ²⁾	V_{Rd}	[kN]	12,0	18,4	27,2	50,4	n/a	n/a
A4-70	Tensile	N_{Rd}	[kN]	9,5	12,6	18,4	27,9	n/a	n/a
	Shear ²⁾	V_{Rd}	[kN]	8,3	12,8	19,2	35,3	n/a	n/a

Recommended Loads see page 4.

Supplied by



Making your job easier!

09 42 68 101

sales@everitts.co.nz

www.everitts.co.nz



Performance Data¹⁾ for Hammer/Air Drilled Holes in Non-Cracked Concrete

Recommended Loads³⁾ Dry/Wet Holes

Steel Failure

Non-Cracked Concrete		D _a		M8	M10	M12	M16	M20	M24
Steel 5.8	Tensile	N _{rec}	[kN]	6,8	9,0	13,2	19,9	33,9	50,3
	Shear ²⁾	V _{rec}	[kN]	5,1	8,0	12,0	22,3	34,9	50,3
Steel 8.8	Tensile	N _{rec}	[kN]	6,8	9,0	13,2	19,9	33,9	50,3
	Shear ²⁾	V _{rec}	[kN]	8,6	13,1	19,4	36,0	56,0	80,6
A4-70	Tensile	N _{rec}	[kN]	6,8	9,0	13,2	19,9	33,9	50,3
	Shear ²⁾	V _{rec}	[kN]	6,0	9,2	13,7	25,2	39,4	56,8

Recommended Loads³⁾ Flooded Holes

Non-Cracked Concrete		D _a		M8	M10	M12	M16	M20	M24
Steel 5.8	Tensile	N _{rec}	[kN]	6,8	9,0	13,2	19,9	n/a	n/a
	Shear ²⁾	V _{rec}	[kN]	5,1	8,0	12,0	22,3	n/a	n/a
Steel 8.8	Tensile	N _{rec}	[kN]	6,8	9,0	13,2	19,9	n/a	n/a
	Shear ²⁾	V _{rec}	[kN]	8,6	13,1	19,4	36,0	n/a	n/a
A4-70	Tensile	N _{rec}	[kN]	6,8	9,0	13,2	19,9	n/a	n/a
	Shear ²⁾	V _{rec}	[kN]	6,0	9,2	13,7	25,2	n/a	n/a



INNOVATIVE SOFTWARE - ANCHOR DESIGN MADE EASY

- Innovative 3d visual user interface, ETAG-001 & SA TS 101:2015 compliant
- SEISMIC DESIGN under earthquake loads according to ETAG-001, Annex E, TR045
- Finite element analysis steel baseplate design

ICCONS® DesignFIX Software is simple, intuitive and FREE to DOWNLOAD anchor design program for Design Engineers, Project Managers, Site Engineers and End Users. Complex mechanical or chemical heavy duty anchor arrangements can be calculated in minutes. All designs are ETA based and qualify under the newly released SA TS 101:2015 now directly referenced in the 2016 National Construction Code.

With input Freedom & 3D user Interface ICCONS® DesignFIX offers complete

freedom to select an anchor pattern and base plate configuration, as well as the position and direction of load combinations. Changes are made directly into the 3D user interface.

Anchor Type Comparison

ICCONS® DesignFIX displays the usability of the various anchor types (according to ETAG-001, Annex C, TR029), including the values for each load type. This allows you to compare the calculation result of the different anchor types in a single easy to read panel.

Optimum BIS Injection System Anchorage Depth when selecting a BIS Injection Mortar.

ICCONS® DesignFIX allows for the automatic calculation of the most effective anchorage depth, taking in consideration the minimal and maximum values of the ETA. The integrated FEM-Calculation Method (Finite Element Method) in ICCONS® DesignFIX allows you to calculate the base plate thickness based upon the stresses in the base plate combination with the base plate configuration.



FREE DOWNLOAD!

www.iccons.com.au



AEFAC
www.aefac.org.au

Supplied by



Making your job easier!

09 42 68 101

sales@everitts.co.nz
www.everitts.co.nz